

Ra	0.2	▽▽▽▽	JIS
1.6	▽▽	▽▽	
6.3	▽	▽	
25	▽	▽	

±0.1	0.5~5
±0.2	6~30
±0.3	31~120
±0.5	121~320
±0.8	321~1000

GENERAL TOLERANCE

Ohio Valve Company
 4061 Clough Woods
 Drive Batavia, OH 45103
 Tel: 513-752-5600 Fax: 513-752-8267
 E-mail: sales@ohiovalve.com
 www.ohiovalve.com

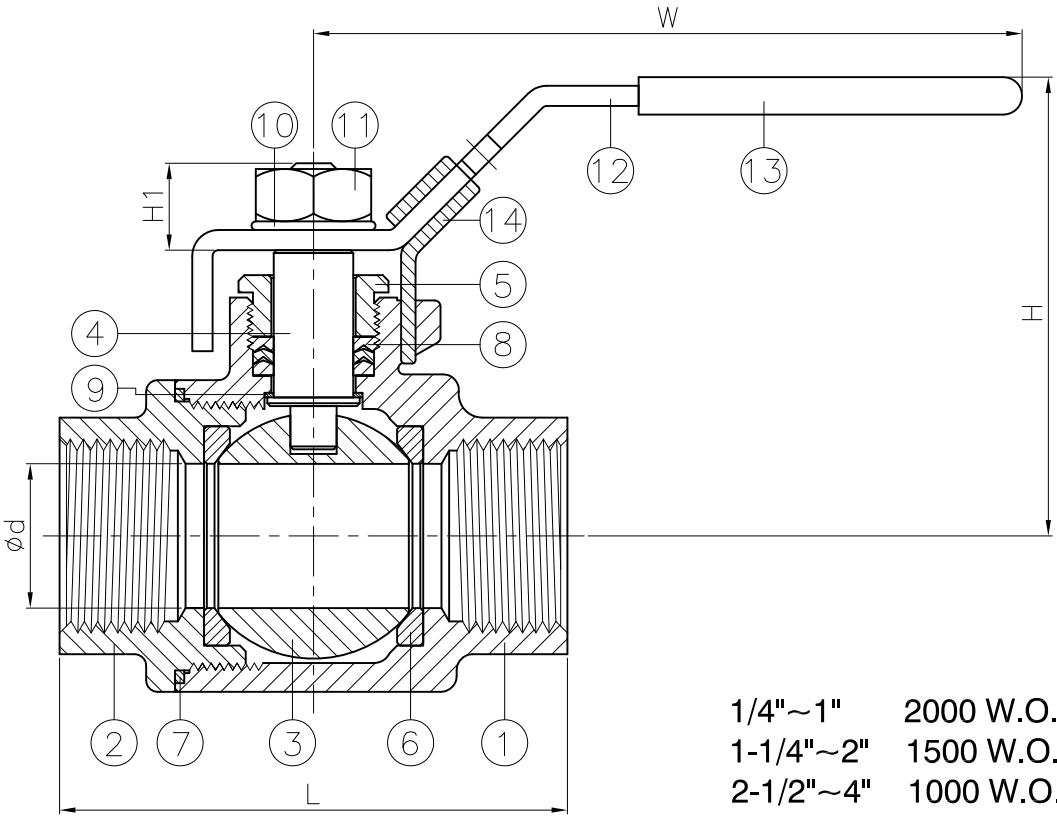
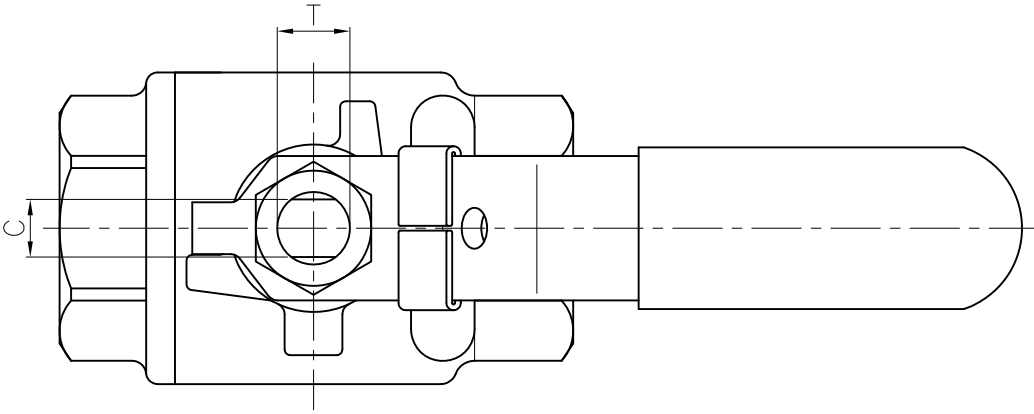

1/4"~1" 2000 W.O.G.
 1-1/4"~2" 1500 W.O.G.
 2-1/2"~4" 1000 W.O.G.

DN	d	L	W	H	H1	T	C	Torque (N-M)		Weight (kg)
								Action	Breakaway	
8	11.6	60.5	102	53.6	10.5	5/16"	5	3.6	5.1	0.4
10	12.8	60.5	102	53.6	10.5	5/16"	5	3.8	6.4	0.3
15	15	62.5	102	57	10.5	5/16"	5	3.8	6.4	0.4
20	20.2	77	124	62.1	13.5	3/8"	6.5	3.8	6.4	0.6
25	25.6	90	165	80	15.7	7/16"	8	7.7	11.4	1.1
32	32	100	165	83.7	15.7	7/16"	8	19.5	28.6	1.6
40	38	118	188	99	17	1/2"	9	19.5	32.5	2.3
50	50.8	138	188	107	17	1/2"	9	20.8	44.2	3.8
65	65.5	167	250	142	27.5	3/4"	12	33	55	5.5
80	80	193	250	153	27.5	3/4"	12	42	70	10.6
100	100	258	324	180	34	1"	16	54	90	19.1

unit:mm

NPS	d	L	W	H	H1	T	C	Torque (in-lb)		Weight (lb)
								Action	Breakaway	
1/4"	0.46	2.38	4.02	2.11	0.41	5/16"	0.2	31.9	45.1	0.9
3/8"	0.5	2.38	4.02	2.11	0.41	5/16"	0.2	33.6	56.6	0.7
1/2"	0.59	2.46	4.02	2.24	0.41	5/16"	0.2	33.6	56.6	0.9
3/4"	0.8	3.03	4.88	2.44	0.53	3/8"	0.26	33.6	56.6	1.3
1"	1.01	3.54	6.5	3.15	0.62	7/16"	0.31	68.2	100.9	2.4
1-1/4"	1.26	3.94	6.5	3.3	0.62	7/16"	0.31	172.6	253.1	3.5
1-1/2"	1.5	4.65	7.4	3.9	0.67	1/2"	0.35	172.6	287.6	5.1
2"	2	5.43	7.4	4.21	0.67	1/2"	0.35	184.1	391.2	8.4
2-1/2"	2.58	6.57	9.84	5.59	1.08	3/4"	0.47	292.1	486.8	12.1
3"	3.15	7.6	9.84	6.02	1.08	3/4"	0.47	371.7	619.5	23.4
4"	3.94	10.16	12.76	7.09	1.34	1"	0.63	477.9	796.6	42.1

unit:in

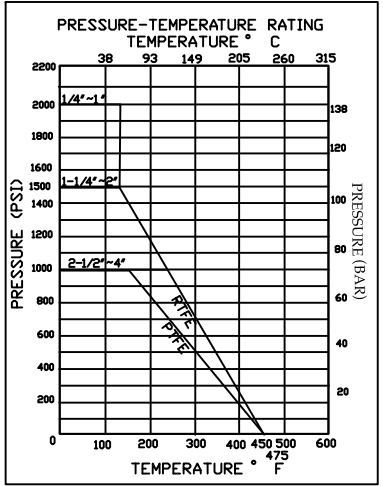

ITEM	PARTS	MATERIAL
1	BODY	ASTM A216-WCB
2	CAP	
3	BALL	ASTM A351-CF8M
4	STEM	ASTM A276-316
5	GLAND NUT	AISI 304
6	SEAT	PTFE / RTFE
7	SEAL	PTFE
8	PACKING	
9	THRUST WASHER	AISI 304
10	SPRING WASHER	
11	NUT	STAINLESS STEEL
12	HANDLE	
13	HANDLE SLEEVE	PVC
14	LOCK DEVICE	STAINLESS STEEL



CHECK BY	DRAWING BY	DATE	SPECIFICATION	2-PC Screwed End Ball Valve
	<i>Jammy</i>	Nov.25.2014	MATERIAL	WCB
			PROCESS/Nr.	
			UNIT / SCALE	mm

△			
△			
△			
Revise	Description	Date	Approve
DRAWING NO.		256-FT	