

Ra	0.2	▽▽▽
	1.6	▽▽
	6.3	▽
	25	▽

± 0.1	0.5-5
± 0.2	6-30
± 0.3	31-120
± 0.5	121-320
± 0.8	321-1000

GENERAL TOLERANCE

E-mail:sales@ohiovalve.com  
 Ohio Valve Company  
 4061 Clough Woods Drive Batavia, OH 45103  
 Tel:513-752-5600 Fax:513-752-8267  
 www.ohiovalve.com

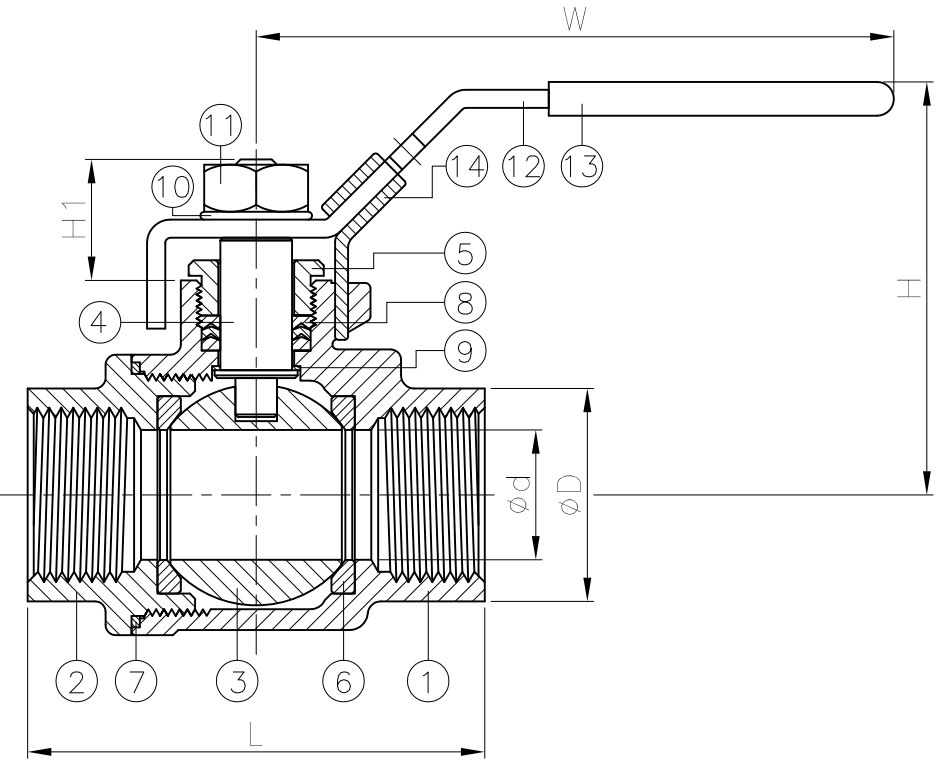
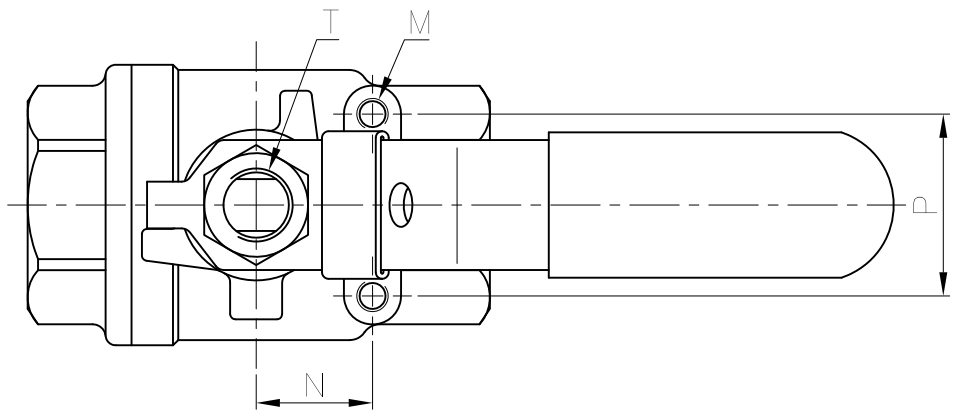

DN	d	D	L	H	H1	T	W	N	P	M	Torque (N-m)	Weight (Kg)
8	11.6	19	50.8	58.5	18	3/8"-24UNF	100	12.7	28.5	M5	3.5	0.2
10	12.5	22.5	50.8	58.5	18	3/8"-24UNF	100	12.7	28.5	M5	4	0.2
15	15	26	58	58.5	18.5	3/8"-24UNF	100	12.7	28.5	M5	5.5	0.3

unit:mm

NPS	d	D	L	H	H1	T	W	N	P	M	Torque (In-lb)	Weight (Lb)
1/4"	0.46	0.75	2	2.3	0.71	3/8"-24UNF	3.94	0.5	1.12	3/16"	31	0.5
3/8"	0.49	0.89	2	2.3	0.71	3/8"-24UNF	3.94	0.5	1.12	3/16"	35.4	0.5
1/2"	0.59	1.02	2.28	2.3	0.73	3/8"-24UNF	3.94	0.5	1.12	3/16"	48.7	0.7

unit:in

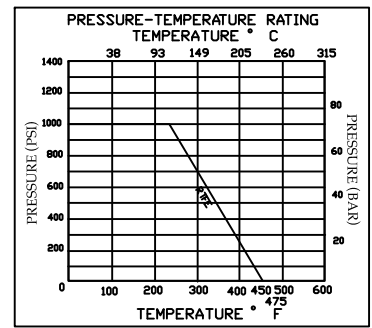

ITEM	PARTS	MATERIAL
1	BODY	ASTM A351-CF8M
2	CAP	
3	BALL	ASTM A276-316
4	STEM	
5	GLAND	AISI 304
6	SEAT	RTFE
7	SEAL	PTFE
8	PACKING	
9	THRUST WASHER	
10	SPRING WASHER	AISI 304
11	NUT	
12	HANDLE	STAINLESS STEEL
13	HANDLE SLEEVE	PVC
14	LOCK DEVICE	STAINLESS STEEL



CHECK BY	DRAWING BY	DATE	SPECIFICATION	2-PC Screwed End Ball Valve 1000 WOG
	Sammy	Nov.25.2014	MATERIAL	CF8M
			PROCESS/Nr.	
			UNIT / SCALE	mm

△			
△			
△			
Revise	Description	Date	Approve
DRAWING NO. 266-FTS			

Ra	0.2	▽▽▽
1.6	▽▽	▽▽▽
6.3	▽	▽▽
25	▽	▽
▽	~	~

± 0.1	0.5-5
± 0.2	6-30
± 0.3	31-120
± 0.5	121-320
± 0.8	321-1000

GENERAL TOLERANCE

E-mail:sales@ohiovalve.com  
 www.ohiovalve.com  
 Drive Batavia, OH 45103  
 Tel:513-752-5600 Fax:513-752-8267

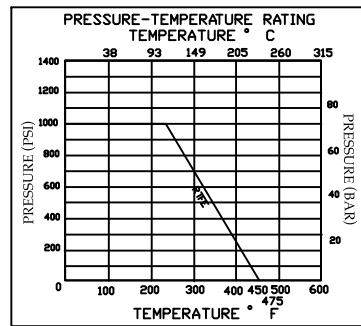
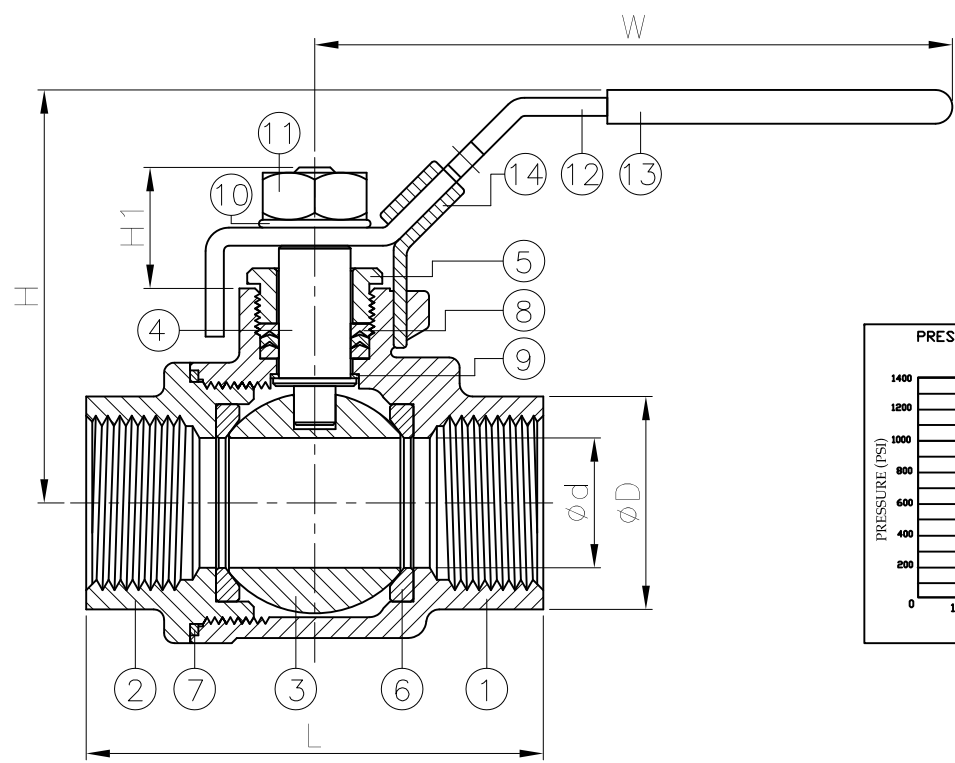
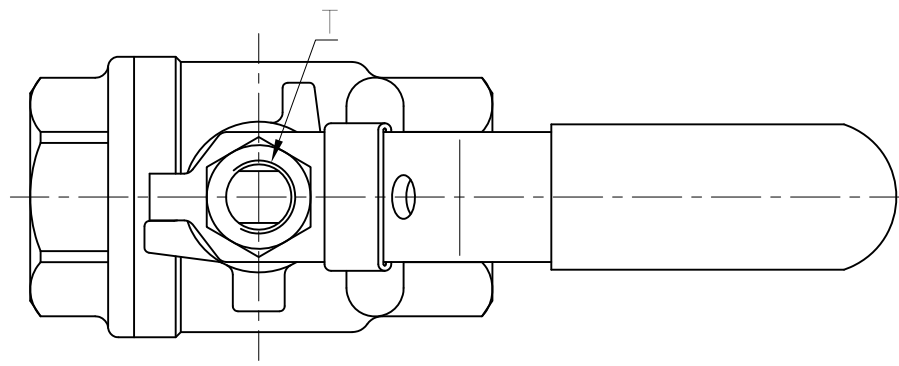

DN	d	D	L	H	H1	T	W	Torque (N-m)	Weight (kg)
20	20	32	65.6	63.5	31.8	7/16"-20UNF	125	7.5	0.5
25	25	38	78.7	78	39.4	7/16"-20UNF	149	11	0.8
32	32	48	90	83	37.9	7/16"-20UNF	149	15	1.1
40	38	54.8	105	102	43.4	1/2"-20UNF	190	20	1.8
50	50	67	124	108	42	1/2"-20UNF	190	40	2.7
65	63	85	146	138	54.8	3/4"-10UNF	250	60	5.6
80	76	100	164	146	55.8	3/4"-10UNF	250	85	7.5

unit:mm

NPS	d	D	L	H	H1	T	W	Torque (in-lb)	Weight (lb)
3/4"	0.79	1.26	2.58	2.5	1.25	7/16"-20UNF	4.92	66.4	1
1"	0.98	1.5	3.1	3.07	1.55	7/16"-20UNF	5.87	97.4	1.7
1-1/4"	1.26	1.89	3.54	3.27	1.49	7/16"-20UNF	5.87	132.8	2.5
1-1/2"	1.5	2.16	4.13	4.02	1.71	1/2"-20UNF	7.48	177	3.9
2"	1.97	2.64	4.88	4.25	1.65	1/2"-20UNF	7.48	354	5.9
2-1/2"	2.48	3.35	5.75	5.43	2.16	3/4"-10UNF	9.84	531	12.4
3"	2.99	3.94	6.46	5.75	2.20	3/4"-10UNF	9.84	752.3	16.5

unit:in

ITEM	PARTS	MATERIAL
1	BODY	ASTM A351-CF8M
2	CAP	
3	BALL	ASTM A276-316
4	STEM	
5	GLAND	AISI 304
6	SEAT	RTFE
7	SEAL	PTFE
8	PACKING	
9	THRUST WASHER	AISI 304
10	SPRING WASHER	
11	NUT	STAINLESS STEEL
12	HANDLE	
13	HANDLE SLEEVE	PVC
14	LOCK DEVICE	STAINLESS STEEL



CHECK BY	DRAWING BY	DATE	SPECIFICATION	2-PC Screwed End Ball Valve 1000 WOG
	<i>Sammy</i>	Nov.25.2014	MATERIAL	CF8M
			PROCESS/Nr.	
			UNIT / SCALE	mm

△			
△			
△			
Revise	Description	Date	Approve
DRAWING NO.		266-FTS	